

View of interiors - Centerline to port

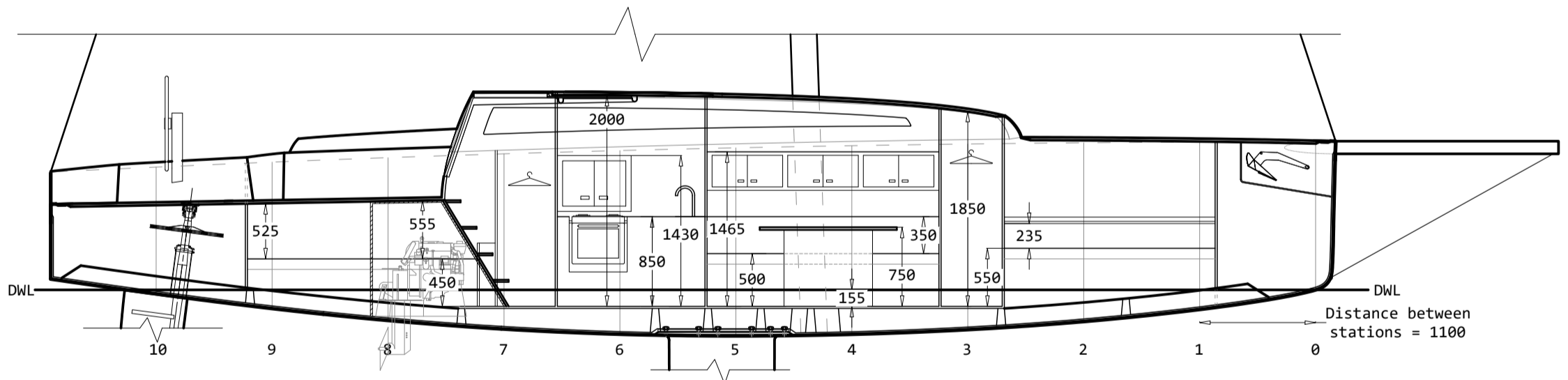

View of interiors - Top view

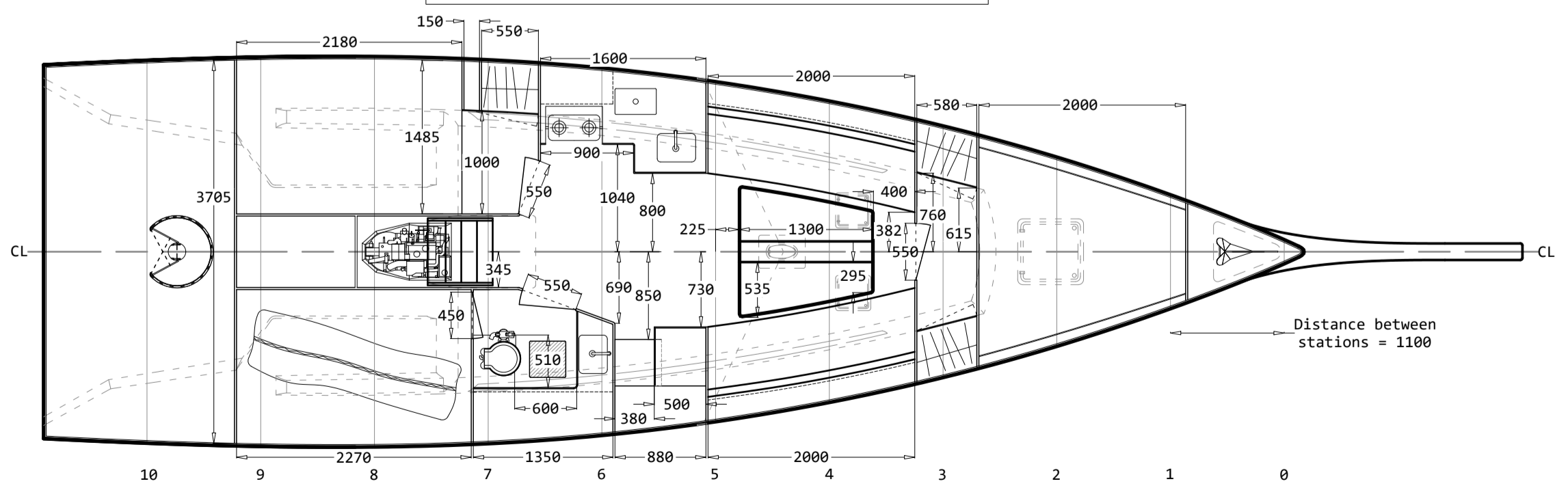

Boat data (light)	
LOA	12.19
LWL	11.28
B	3.78
D	2.70
RM@1	251.92
RM@30	7217.29
Δ	6262
Tc	0.44

Rig data	
P	16.40
E	5.70
I	16.60
J	4.90
ISP	17.90
TPS	7.00
BAS	1.71
CPW/2	1.65



UNQ

Sketch exterior & interior

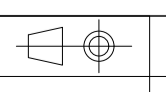

TP02

22/08/2022

Till Raguin

Arquitectura Naval

Proyecto final

Prof.: Handoztok

R4

Scale 1:50 @ A2