

Mast data (full load)		
Section	Seldén	CC263-48
MDL	266	mm
MDT	136	mm
Iy_r	2396	cm ⁴
Iy_a	2380	cm ⁴
FS_y_a	0.99	-
Ix_r	597	cm ⁴
Ix_a	824	cm ⁴
FS_x_a	1.38	-
Weight	4.8	kg/m

Scale 5:1

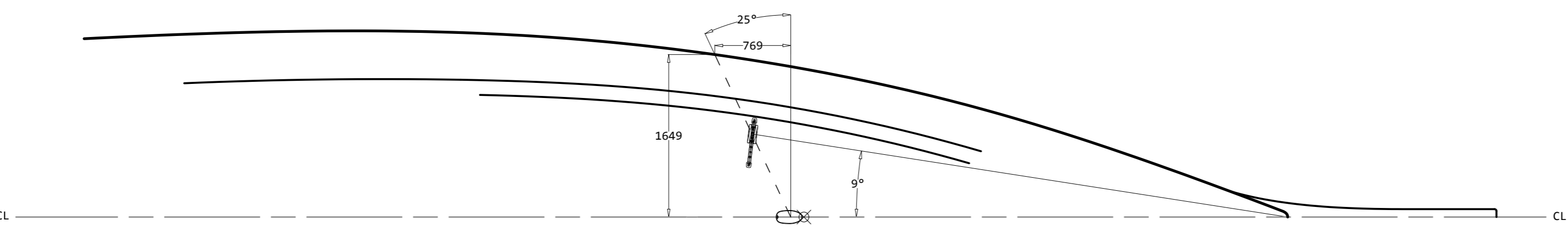
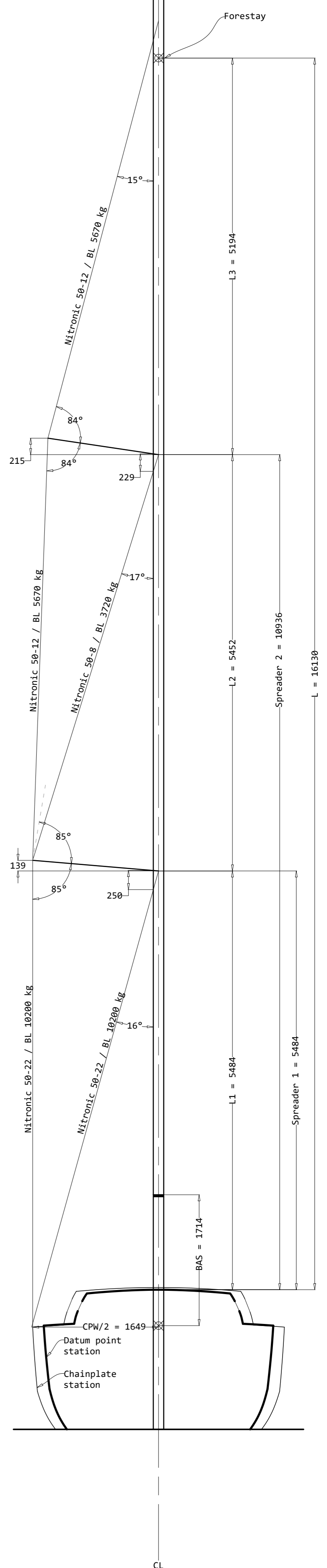
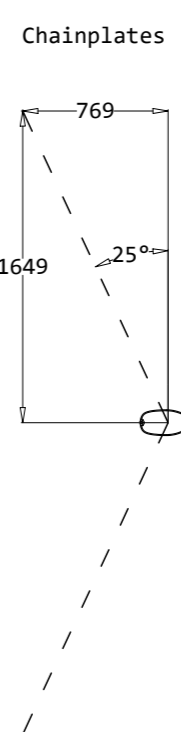
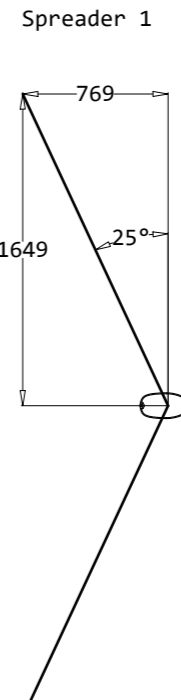
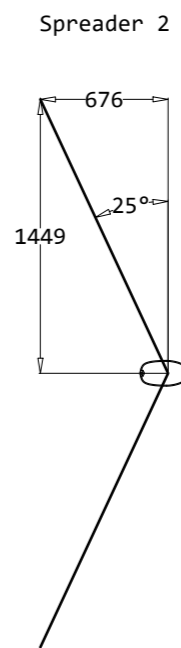
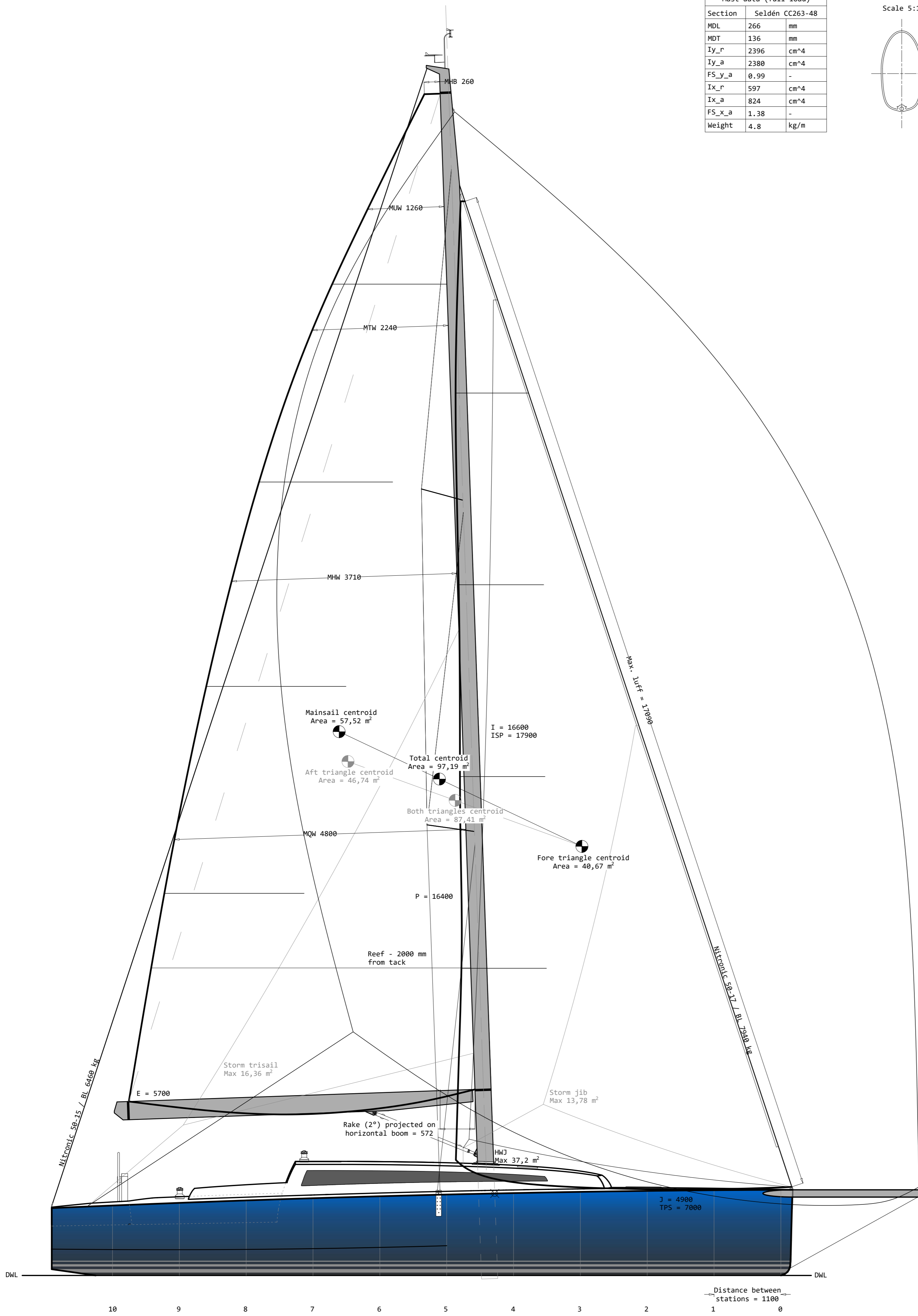
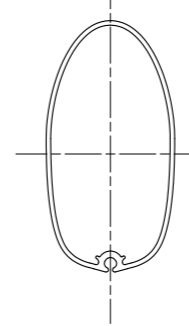

Mainsail	
MHB	0.26
MUW	1.26
MTW	2.24
MHW	3.71
MQW	4.80
Jib	
HHB	0.07
HUW	0.83
HTW	1.57
HW	2.90
HQW	4.10
HLP	5.25
HLU	17.09
Spinnaker	
SLU	20.47
SLE	17.14
SHW	11.98

Rig data	
P	16.40
E	5.70
I	16.60
J	4.90
ISP	17.90
TPS	7.00
BAS	1.71
CPW/2	1.65

Sail data	
P/E	2.88
I/J	3.39
SA/WSA	3.97
SA/	5.61
DA	16.61

Boat data (light)	
LOA	12.19
LWL	11.28
B	3.78
D	2.70
RM@1	251.92
RM@30	7217.29
Δ	6262
Tc	0.44

All measurements in millimetres except for the dimensions in these four charts.